

Waiver:

This sheet is for guidance only and must not be used for proper working drawings. Please contact Lehner Liftechnik for particular details before proceeding. Owing to our policy of continual improvement we reserve the right to alter specifications and dimensions without prior notice.

DELTA
Wheelchair Platform Stairlift
Loads & Fixings
For guidance only



Aug, 2004

Mounting Methods

- The stairlift can be mounted on support pillars or directly on the wall.
- A mounting method should be chosen such that the applied loads are adequately supported.
- Support pillars can be arranged in a variety of ways to suit the application:
 1. With footplate fixed directly to tread.
 2. With footplate fixed to tread & additionally braced horizontally into wall.

Applied Load

The applied load from the lift is shown in the diagram below; transfer of these loads into the building structure depends on the fixing arrangement. Some examples are shown in adjacent Load Sketches.

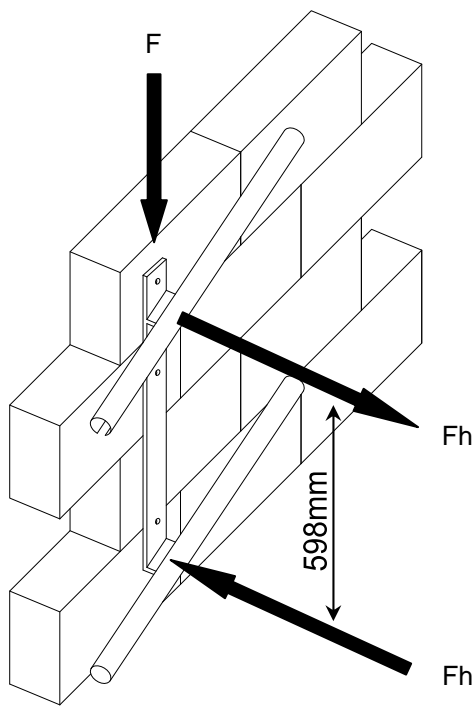

Fixings

Fixings will be chosen appropriate for the substrate material. Proposals will be made following site survey, but instructions from the customer or his engineers will also be taken into account. Fixings may be: normal, coach or expansion bolts, stud & chemical resin or combinations thereof. Additional brackets, spreader plates etc. can be provided where needed.

For a load capacity of max.300kg with a platform width of max.800mm the following values of forces are suitable:

$F = 4003N * 1.5$ $Fh = 3414 * 1.5$ (1.5 = shock factor)

F = 6005N
Fh = 5121N

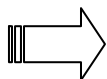

Calculation in case of Pillars	z	F2	F3
Standard Base Plate	115mm	/	/
Long Diamond Base Plate	150mm	21047N	14031 N

Load sketches

Applied loads in fixings shown

Treat Mount – Long Diamond Base Plate

Treat Mount + Brace

Wall Mounted

Attention!
If this distance becomes larger, the forces are growing also!

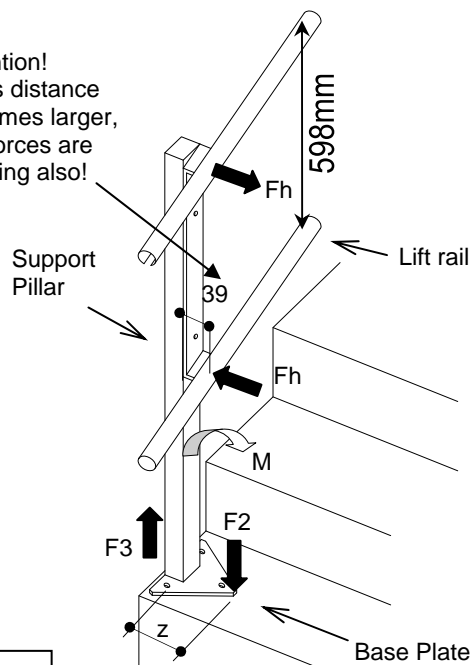

F = 6005N
Fh = 5121N