



STRATOS NG

PLATFORM STAIRLIFT

THE NEXT GENERATION

Proven technology rethought

- High-resolution color display with status display
- Reduced space requirement
- Powerful 0.75 kW motor
- LED platform lighting
- Ergonomically positioned control panel
- Electric emergency lowering system
- Motorized side ramp (optional)

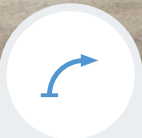
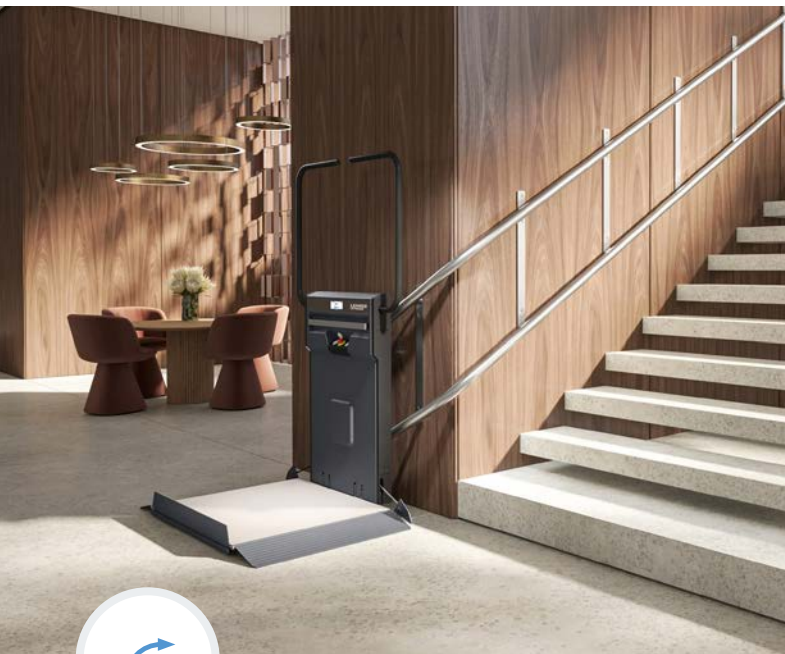
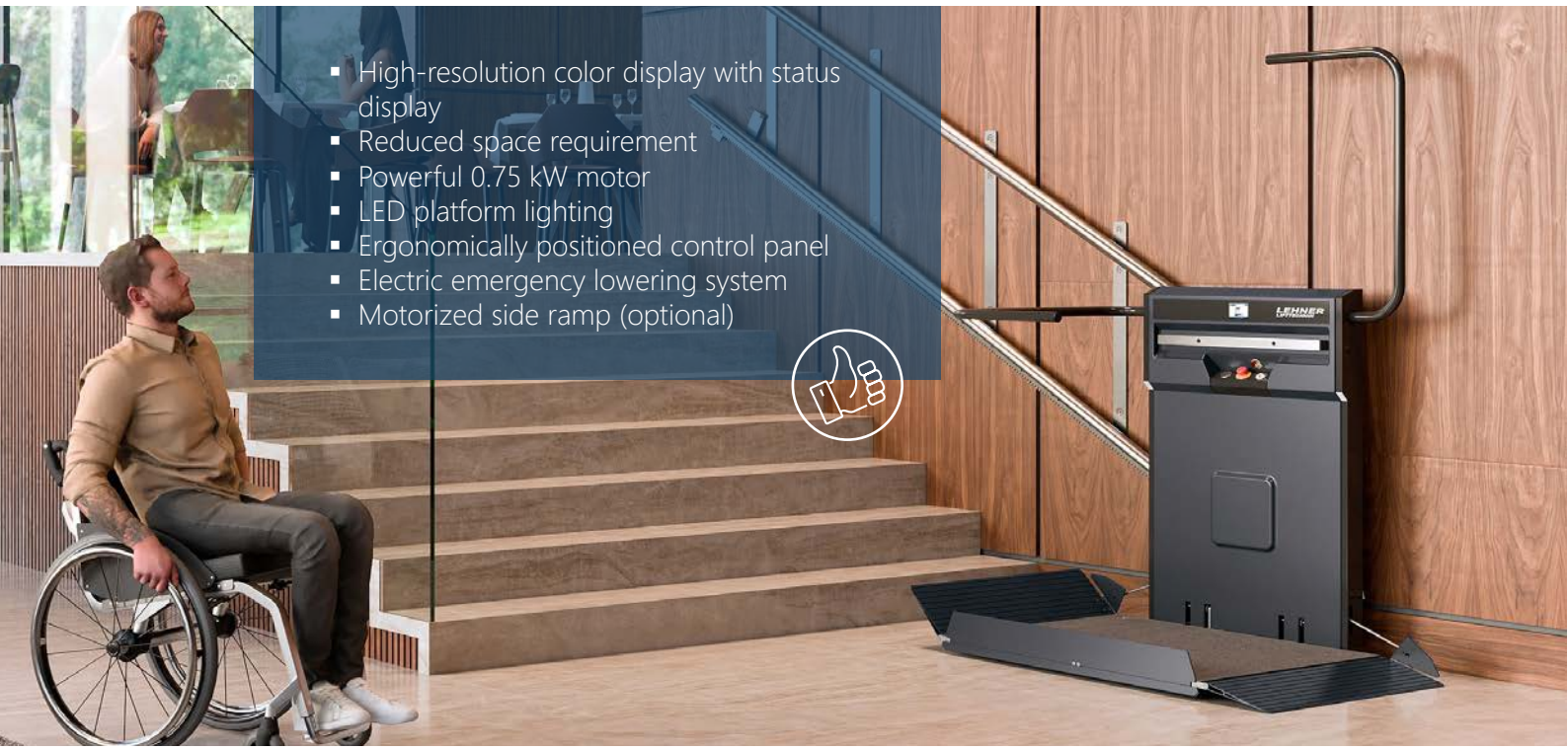

The STRATOS for curved stairs

masters the tightest curve radii and steep flights of stairs. The curved version offers an efficient solution for a wide range of conditions.

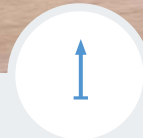
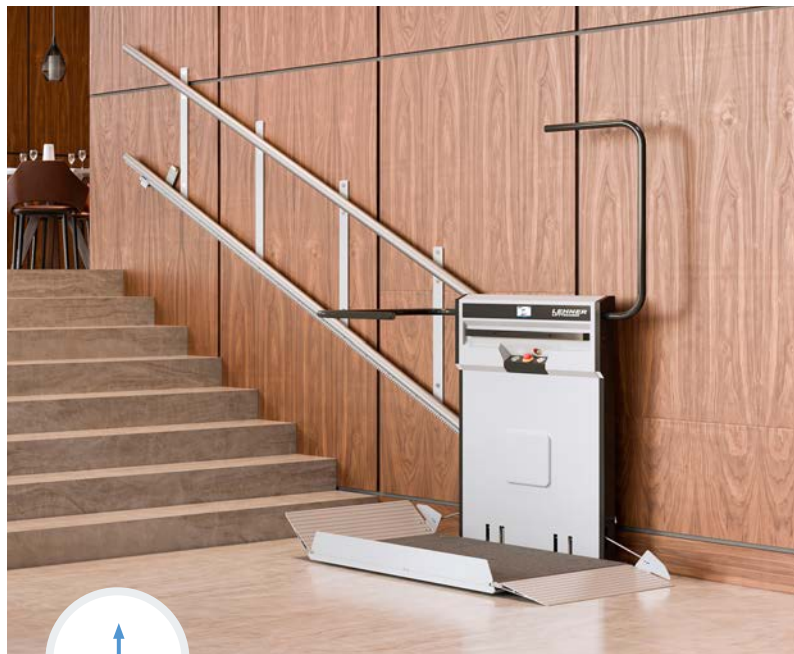

The STRATOS for straight stairs

handles inclines of up to 60° effortlessly. The straight version can also be ordered with an aluminum rail

MULTI-TALENT

Additional comfort thanks to improved equipment



Equipped with the most powerful engine in its class





Color display with status indicator and ergonomic control panel



Slim, timeless design

Technical specifications

Loading capacity	225 kg (optional 350 kg)
Platform sizes	700 x 750 mm, 750 x 850 mm, 800 x 900 mm, 800 x 1000 mm
Gradient	0 - 60°
Folded width	295 mm
Drive engine	0,75 kW
Max. rail length	60 m
Speed	up to 0,12 m/s
Rail diameter	50 mm
Indoor use	✓
Outdoor use	✓
Standard colour	<div style="display: flex; justify-content: space-around; align-items: center;"> <div style="text-align: center;">  RAL 7016 </div> <div style="text-align: center;">  RAL 9003 </div> </div>

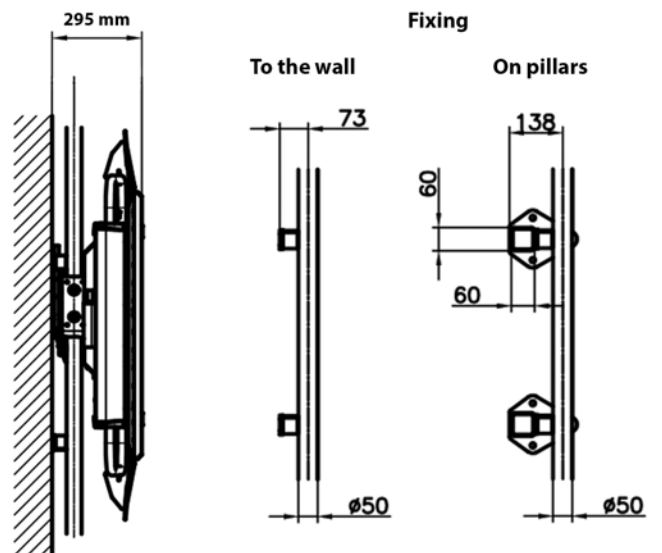



Platform stairlifts



Chair stairlifts



Vertical platformlifts



Special lifts



Poollift



Contact your dealer for
further information:



Official partner of:

LEHNER
LIFTTECHNIK

Lehner Liftechnik GmbH

Salling 8
4724 Neukirchen am Walde
Österreich
+43 7278 35 14
sales@lehnerlifttechnik.at
www.lehner-liftechnik.at

05/2025