

Cutout dimension see sheet
2, forces see sheet 3

*To be adapted on site
**Customized panel

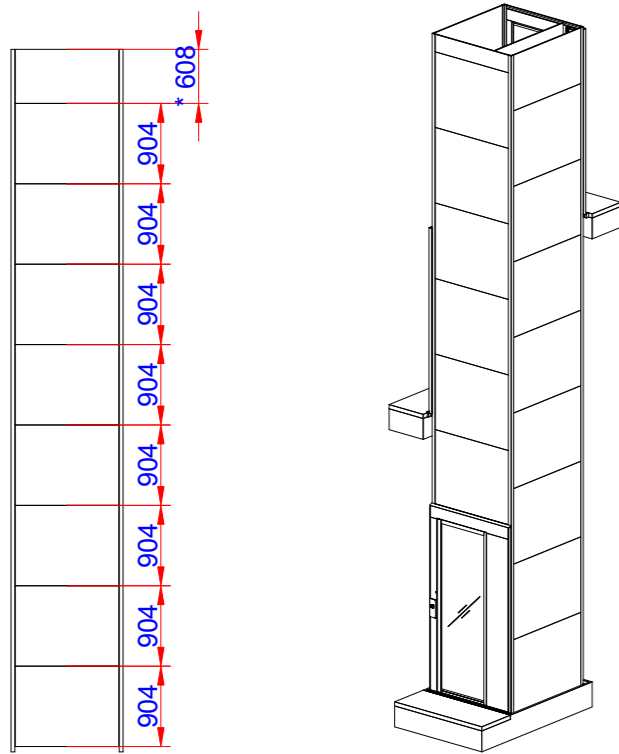

E

Positioning of machinery:

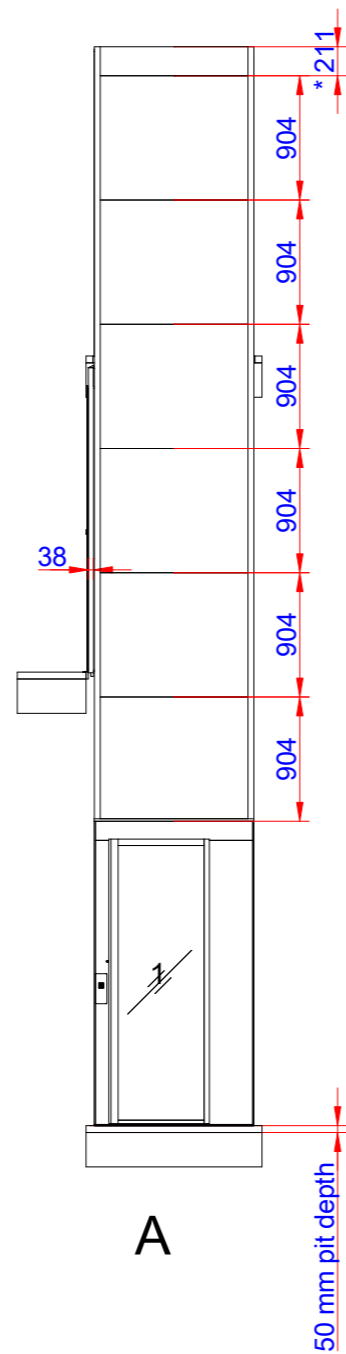
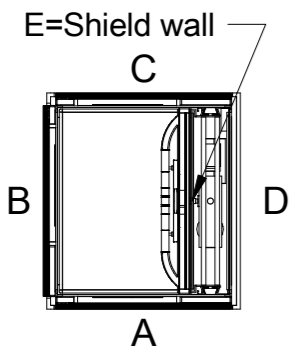

A

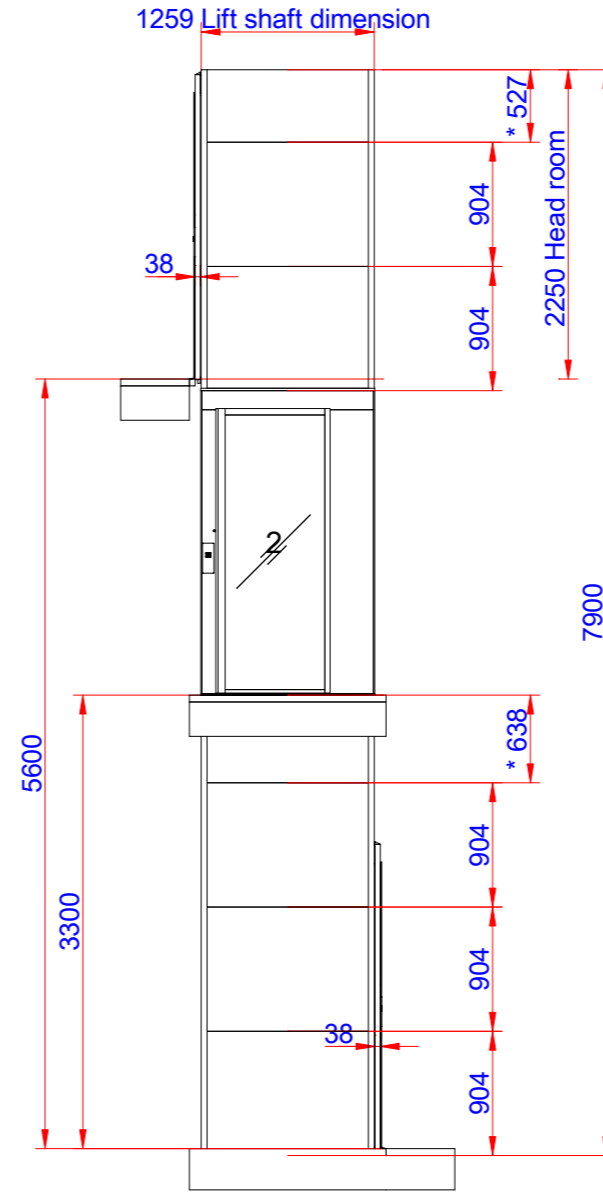

B

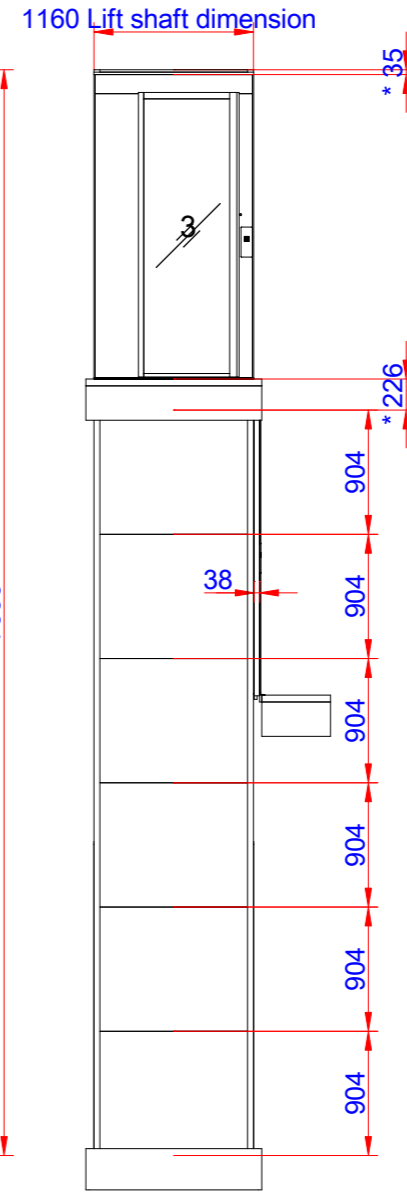

C

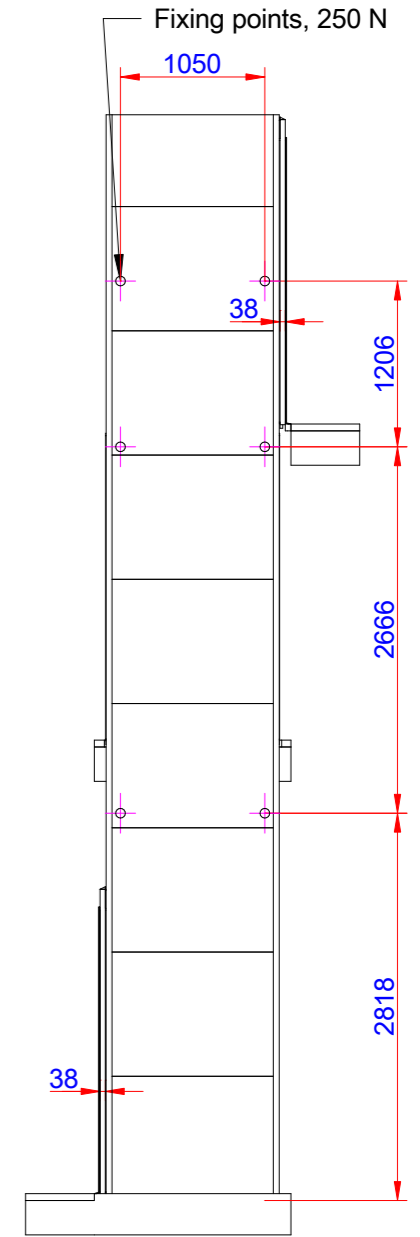

D

Options
Frekv 1x230/240V 50-60Hz 16 A Soft
Capacity: 400,00 kg

Approved by
builder:

European view placement:



EOS ID	Principal drawing		
Tender no	Air - 800*1217		
Order no	Shaft drawing		
Gen. Tolerances	Date	sheet	Scale:
SS-ISO 27681-1 m		1 of 7	A3, 1:55

Shaft cutout sizes

Lift unit installed within a shaft by others

Door front cutout sizes		
Landing	Width	Height
A 1	1230	2250
B 2	1380	2250
C 3	1230	2250

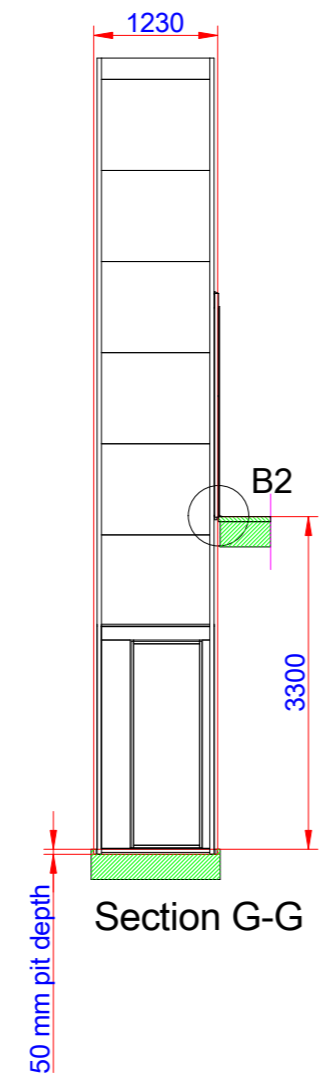
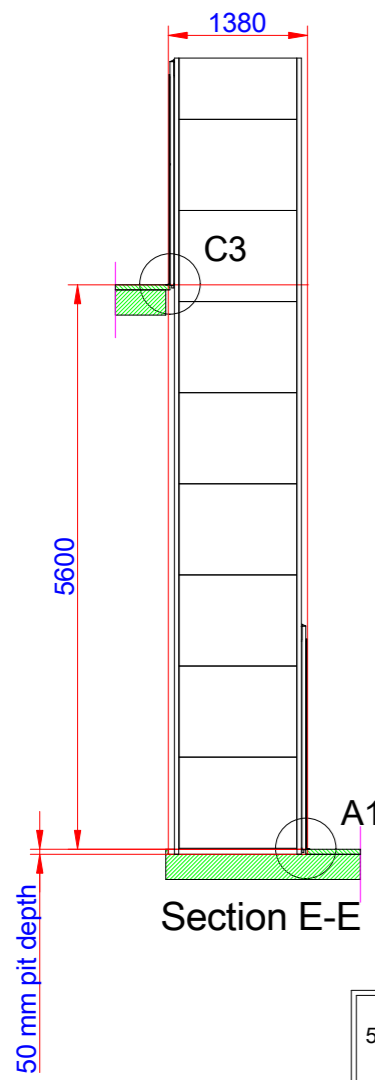
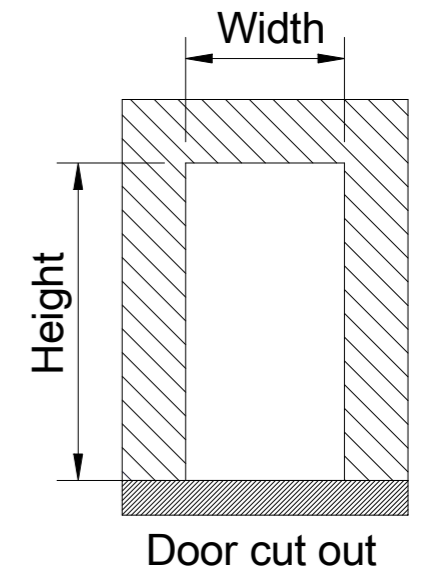

50 mm pit depth + 10 mm, - 0 mm.
Bottom surface must be flat

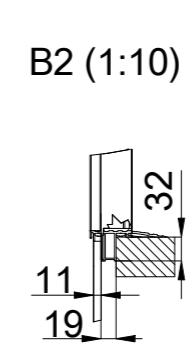
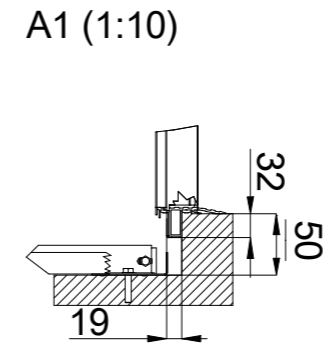
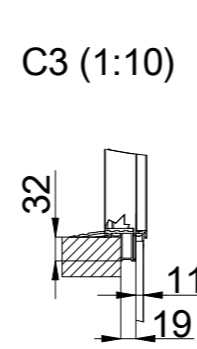
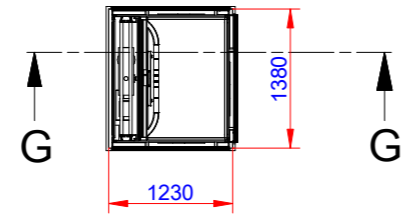
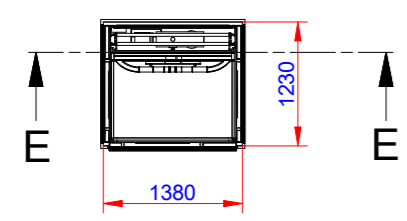

Incoming power supply is connected at landing:
For wiring and power supply, refer to the unit's wiring diagrams.
Ceiling shaft lighting, is independent from the power cable and pulled back into the trench's upper part. Shaft lighting > 50 lux.
NOTE! An effective emergency telephone is required for approved inspection.
The purchaser is responsible for an active phone line being present prior to the lift installation.
The incoming telephone line is connected to CiLow (TELE). Refer to wiring diagram.
The emergency signal device is powered by the lift's own battery in the event of a power failure.
The lift must be equipped with a two-way communication, either via the standard telephone or via the lift telephone, which automatically calls the alarm control center or the like.
NOTE! A lift featuring a frequency converter cannot be directly connected to a RCD.

Approved by builder:

European view placement:



EOS ID
Tender no
Order no
Gen. Tolerances
SS-ISO 27681-1 m

Principal drawing
A 5000 - 800*1217
Cut out sizes
Date
sheet 2 of 7
Scale: A3, 1:55